

Product Specification of:

## O<sub>2</sub> - Medical Sensor:

Type: SS-01

Part. No.:

**Key Features:** Current output gas sensor that shows high signal stability at low cross interferences to anesthesia gases combined with superior linearity over the entire range

All characteristics are based on conditions at 25°C, 50% RH and 1013 hPa

Electrical Connector:	gold-plated slip rings on PCB
Measurement Range:	0 to 100 Vol. %
Nominal Sensor Life:	> 300, 000 Vol. % h
Output Signal:	200 µA ± 40 µA, @ dry ambient air
Response Time $t_{90}$ :	< 20 s
Drift:	< 2 % volume O <sub>2</sub> / month @ air
Operating Temperature:	0 to 40°C
Pressure Range:	750 to 1250 hPa
Linearity Error:	≤ 3 % @ 100 % O <sub>2</sub> applied for 5 minutes
Offset:	less than 0.4% of oxygen equivalent @ 25°C in 100% N <sub>2</sub> applied for 3 min
Repeatability:	± 1 % volume O <sub>2</sub> @ 100 % O <sub>2</sub> , applied for 5 min
Influence of Humidity:	-0.03% rel. O <sub>2</sub> reading per % RH
Interferences:	according to DIN EN 12598 and ISO 7767

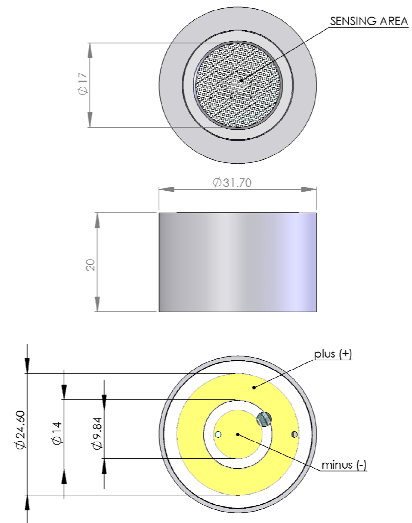

Tolerance: ± 0.15 mm

### Storage Conditions

Temperature Range:	recommended: 5 to 30°C maximum: - 20 to 50°C
Humidity:	up to 100% RH
Shelf Life:	< 3 months
Weight:	approximately 32 g
Material in Contact with Media:	CPVC, PPS, PTFE, stainless steel
Warranty Period:	12 months
Housing Colour:	grey