

Product Specification of:

## O<sub>2</sub> - Medical Sensor:

Type: SS-12AIR

Part. No.:

**Key Features:** Cell that has high signal stability at low cross interferences to anesthesia gases combined with superior linearity over the entire range

All characteristics are based on conditions at 25°C, 50% RH and 1013 hPa

Electrical Connector:	3-pin Molex
Measurement Range:	0 to 100 Vol.%
Nominal Sensor Life:	> 500 000 Vol.% h
Expected Operating Life:	< 3 years @ ambient air
Output Signal:	8.0 to 12.5 mV @ dry ambient air
Response Time $t_{90}$ :	< 12 s
Drift:	< 1% volume O <sub>2</sub> / month @ air
Operating Temperature:	0 to 40°C
Pressure Range:	750 to 1250 hPa
Linearity Error:	≤ 3% @ 100% O <sub>2</sub> applied for 5 min
Zero Offset Voltage:	< 200 μV in 100% N <sub>2</sub> , applied for 5 min
Repeatability:	± 1 % volume O <sub>2</sub> @ 100% O <sub>2</sub> , applied for 5 min
Influence of Humidity:	-0.03% rel. O <sub>2</sub> reading per % RH
Recommended Load Resistor:	≥ 10 kOhm
Temperature Compensation:	NTC
Interferences:	according to DIN EN 12598 and ISO 7767

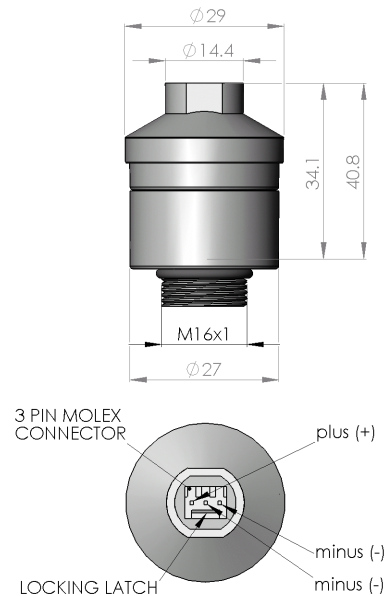

Tolerance: ± 0.15 mm

### Storage Conditions

Temperature Range:	recommended: 5 to 30°C maximum: - 20 to 50°C
Humidity:	up to 100% RH
Shelf Life:	< 6 months
Weight:	approximately 24 g
Material in contact with media:	PA, PPS, PTFE, stainless steel
Warranty Period:	12 months
Housing Colour:	white